

# Fluid Power Intensifiers

## Series PC, PD and PS



The easier, less costly way to provide high pressure hydraulic power.

- Maximum Input Pressures:  
Air - 250 psi (17 BAR);  
Oil - 1000 psi (69 BAR).
- Maximum Output Pressures:  
5/8" to 3" RAM - 5000 psi (345 BAR);  
3 1/2" to 5 1/2" RAM -  
3000 psi (206 BAR).
- Maximum Operating Temperatures:  
-10°F to +165°F (-23°C) to (+74°C).

For Cylinder Division Plant Locations – See Page II.

# Parker Fluidpower Intensifiers

## Designed to Save Energy, Time, Space and Money in a Wide Variety of Applications.

A Parker Fluidpower Intensifier is an efficient way of generating high pressure hydraulic fluid. Its operation is quite simple. Pressurized fluid -either air or oil -enters the intensifier and acts on a confined piston. This in turn drives a smaller diameter ram or piston to deliver a given volume of fluid. As a result, the output pressure is intensified and is considerably higher than the input pressure.

By using a Parker Intensifier you can save in many ways. First, since it requires only low pressure input and less costly control valving, you eliminate the extra expense of high pressure pumps, valving and a large electrical power sources. The simpler mountings and controls also save you valuable installation time.

In addition, since Parker Intensifiers produce high hydraulic pressure, you can save space by using a smaller bore hydraulic cylinder in place of a larger bore air cylinder that is heavier and more costly.

Finally, because of the rugged dependability of Parker Intensifiers and the simpler circuitry required, you eliminate the constant motion, heat generation and power consumption found in pump systems. This means that you use less energy with less downtime and maintenance.

These abilities and benefits of Parker Fluidpower Intensifiers make them the ideal component in many applications. You can use them for such operations as marking, forming, molding, punching, riveting, shearing, straightening, laminating, embossing, welding and testing.

What's more, the Parker Intensifier can be mounted on or off the equipment and can even be integrally combined with the work cylinder. This flexibility makes them particularly useful hydraulic pressure sources on portable equipment.

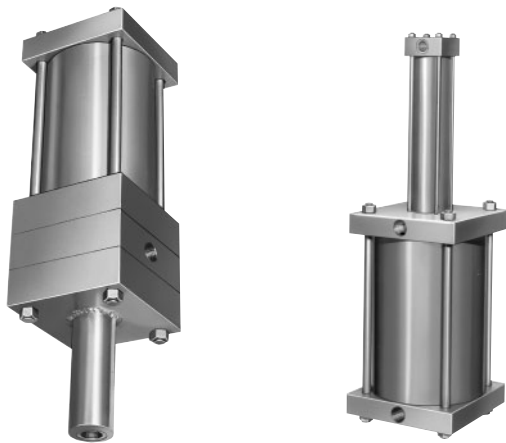

Parker Fluid Intensifiers are available in various sizes and configurations. There are cylinder-to-ram units with capability for either single pressure or dual pressure service (left above), as well as several cylinder-to-cylinder models (above right).

## Here are the features you'll find in every Parker Fluidpower Intensifier:

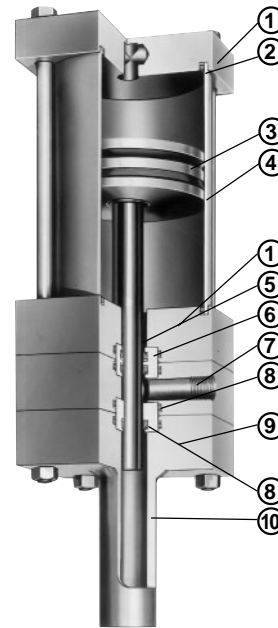

1. Compact, high-strength steel heads, cap and tie rods meet the most demanding applications.
2. Seal by pressure O-rings serve as cylinder body-to-head seals prevent leaks. The cylinder body is also piloted on the O.D. to insure metal-to-metal contact to support the seals.
3. The rugged one-piece iron piston is threaded and Loctited to the ram. Parker Lipseal® piston seals are used with air; piston rings with hydraulic fluid.
4. The driving cylinder body is steel tubing with chrome-plated bore for corrosion-resistance in bore sizes 3 1/4" through 10". Fiber glass is used on 12" and 14" bore sizes.

5. The smooth, wear-resistant surface of the chrome-plated and induction-hardened ram greatly lengthens seal life.
6. Static O-ring seals prevent leaks past the O.D. of the glands. Back-up washers prevent extrusion.
7. Intensifier operation is speeded up by the free flow of fluid in and out of the unobstructed ports. All high-pressure hydraulic ports are SAE straight thread. O-ring type for leak-proof service.
8. Serrated Lipseals® (Patent 2997318) are self-compensating and self-adjusting to provide leakproof ram seal for both high and low pressure operation.
9. For servicing the high pressure ram seals, the pressure chamber is independently secured with studs so it can be easily removed without disassembling the complete intensifier.
10. For optimum strength and safety, the pressure chamber wall is made of extra thick steel tubing that is piloted in a counterbore and pressure-welded to the head.

## Dual Pressure Circuit

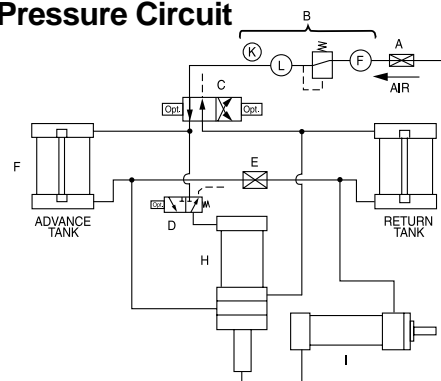

- A Cutoff Valve
- B Air Preparation Unit (Filter Regulator Lubricator-Gauge)
- C 4-Way Valve (Normally 2 Position)
- D 3-Way Valve
- E Cutoff Valve (For Balancing Tank Fluid Levels)
- F Advancing Tank (Air-Oil)
- G Retracting Tank (Air-Oil)
- H Retractor Intensifier
- I Work Cylinder

This basic circuit is for a dual pressure system supplying pressure to a double-acting work system. The circuit may be readily

**For additional information – call your local Parker Cylinder Distributor.**

changed for other operating conditions such as single acting cylinder and single pressure delivery.

The input pressure is introduced to the system through shop air lines to the 4-way directional control valve C. When valve C is shifted to position as shown, air is directed into air-oil tank F and to valve D. Oil, acted upon by air pressure, is forced from tank through pressure chamber of retracted intensifier and into work cylinder. The cylinder advances in stroke, being driven by this incoming oil. At a predetermined point in the stroke length of the work cylinder, valve D is synchronized to shift and direct air pressure to the intensifier to drive it in its power stroke, isolating tank F and supplying high pressure to work cylinder for its high thrust stroke. The work cylinder and intensifier are retracted by the shifting of valves C and D simultaneously to exhaust the intensifier and tank F. At the same time, air pressure is directed to tank G

and to rod end side of intensifier piston. Oil from tank G retracts cylinder at low pressure.

The operators for valves C and D are optional –mechanical, manual, pilot or solenoid. The method of synchronizing valve D to stroke length position of work cylinder is also optional. This may be done by pilot control, limit switch, pressure switch, mechanically such as cams, or manually.

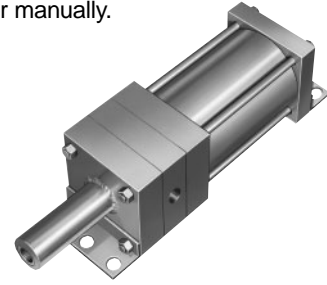

## How to Select Parker Fluidpower Intensifiers

**Step 1:** Determine the intensifier ratio for your application. This is the ratio of the available input fluid pressure and the output operating pressure required for the application. For cylinder-to-ram or cylinder-to-cylinder units, use the following formula:

$$\text{Intensifier ratio} = \frac{\text{Output pressure}}{\text{Input pressure}}$$

**Step 2:** Locate the intensifier ratio in column 5 of the appropriate chart on page 3. If the exact ratio is not shown, use the next larger ratio listed. When more than one choice is possible, usually the smallest driving cylinder bore size for a given intensifier ratio is the most economical answer.

**Step 3:** On same horizontal line as ratio determined in Step 2, select the driving cylinder bore size from column 1 and the ram diameter or driven cylinder bore size from column 3.

**Note:** For cylinder-to-ram applications, proceed with Steps 4 and 5. If a cylinder-to-cylinder unit is required, go to Step 6.

**Step 4:** Determine the type of cylinder-to-ram intensifier needed. Generally, a single pressure intensifier is used when the hydraulic work cylinder requires a high pressure for the entire stroke or in test vessel applications. A dual pressure intensifier is recommended if the high pressure is to be used only during the last portion of the work cylinder stroke.

**Step 5:** Calculate the intensifier stroke.

For single pressure intensifiers, use the formula:

$$\text{Intensifier stroke} = \frac{V + V_C}{A_r}$$

For dual pressure intensifier, use this formula:

$$\text{Intensifier stroke} = \frac{V_h + V_c}{A_r} + 2^{**}$$

Where: V = Work cylinder volume or test vessel fluid requirement in cubic inches.

$V_h$  = oil volume in cubic inches required to move the work cylinder piston through its high pressure stroke.

$V_c$  = compressibility allowance of 1% per 1000 psi of total volume in cubic inches of oil in the high pressure circuit, determined from:

$V_c$  = total volume x .01 x high pressure/1000.

$A_r$  = area of intensifier ram in square inches.

\*This 2" is the intensifier stroke advance necessary to close the high pressure seal on dual pressure intensifiers only.

**Note:** If the calculated intensifier stroke results in a fraction, correct to the next larger **even** inch. The recommended maximum stroke is 20". If stroke calculation results in longer than 20" stroke, select a larger driving cylinder and ram having a similar intensifier ratio and recalculate stroke.

**Step 6:** For cylinder-to-cylinder intensifiers: Select the proper output cylinder. Since the output pressure is limited by the cylinder construction, the cylinder should be selected using the maximum pressure to be developed under nonshock conditions.

For Parker Series 3L and 2H hydraulic cylinders, the maximum pressures under nonshock conditions are:

3L Series: 1 1/2" –2500 psi; 2" –2000 psi; 2 1/2" –1800 psi;  
3 1/4" –2000 psi; 4" –1350 psi; 5" –1500 psi;  
6" –1100 psi; 8" –900 psi

2H Series: All bore sizes –3000 psi.

### General Guidelines

- Intensifiers are generally faster operating when:
  - There is adequate input pressure.
  - The ports and piping are large enough. Consider the use of oversize ports and connecting lines, to minimize pressure drop.
  - The intensifier is pre-exhausted prior to the power stroke.
  - Size hydraulic lines so that fluid flow velocity does not exceed 7 feet per second.
- Bypass the intensifier with a pre-fill low pressure line by direct connection through a check valve to the pressure vessel.
- Regulate the driving pressure to the intensifier to achieve the required high pressure output.
- Keep all piping lengths to a minimum by having the tanks, intensifier and pressure vessel as close together as possible.
- A single pressure intensifier usually provides faster cylinder action because it does not need to change from low to high pressure but instead immediately supplies the high pressure.
- Intensifiers are generally used in circuits where limited quantities of high pressure fluid is required.

**(Series PS and PD) Cylinder to Ram Intensifiers**

Driving Cylinder		Hydraulic Ram			Intensifier Ratio	Theoretical Intensified Hydraulic Pressure (PSI) Using An Input Pressure Of					
Bore	Area	Dia. in	Area of Volume Displ. Per Stroke	50		80	100	200	500	1000	
Col. 1	Col. 2	Col. 3	Col. 4	Col. 5	Col. 6	Col. 7	Col. 8	Col. 9	Col. 10	Col. 11	
3 1/4	8.296	5/8	.307	27.02	1351	2161	2702				
		1	.785	10.57	529	846	1057	2114			
		1 3/8	1.485	5.59	280	447	559	1118	2795		
		1 3/4	2.405	3.45	173	276	345	690	1725	3450	
		2	3.142	2.64	132	211	264	528	1320	2640	
4	12.566	5/8	.307	40.93	2046	3274	4093				
		1	.785	16.00	800	1280	1600	3200			
		1 3/8	1.485	8.46	423	677	846	1692	4230		
		1 3/4	2.405	5.23	262	418	523	1046	2615		
		2	3.142	4.00	200	320	400	800	2000	4000	
		2 1/2	4.909	2.56	128	205	256	512	1280	2560	
5	19.635	5/8	.307	63.95	3197	5116					
		1	.785	25.01	1250	2000	2501	5002			
		1 3/8	1.485	13.22	661	1058	1322	2644			
		1 3/4	2.405	8.16	408	653	816	1632	4080		
		2	3.142	6.25	313	500	625	1250	3125		
		2 1/2	4.909	4.00	200	320	400	800	2000	4000	
		3	7.069	2.78	139	222	278	556	1390	2780	
		3 1/2	9.621	2.04	102	163	204	408	1020	2040	
6	28.274	1	.785	36.01	1800	2880	3601				
		1 3/8	1.485	19.05	953	1524	1905	3810			
		1 3/4	2.405	11.76	588	941	1176	2352			
		2	3.142	9.00	450	720	900	1800	4500		
		2 1/2	4.909	5.76	288	461	576	1152	2880		
		3	7.069	4.00	200	320	400	800	2000	4000	
		3 1/2	9.621	2.94	147	235	294	588	1470	2940	
8	50.265	1	.785	64.03	3201	5122					
		1 3/8	1.485	33.85	1693	2708	3385				
		1 3/4	2.405	20.90	1045	1672	2090	4180			
		2	3.142	16.00	800	1280	1600	3200			
		2 1/2	4.909	10.24	512	819	1024	1048			
		3	7.069	7.11	356	569	711	1422	3555		
		3 1/2	9.621	5.23	262	418	523	1046	1615		
10	78.540	1 3/8	1.485	52.89	2644	4231					
		1 3/4	2.405	32.66	1633	2613	3266				
		2	3.142	25.00	1250	2000	2500	5000			
		2 1/2	4.909	16.00	800	1280	1600	3200			
		3	7.069	11.11	556	889	1111	2222			
		3 1/2	9.621	8.16	408	653	816	1632	4080		
12	113.10	1 3/8	1.485	76.16	3808						
		1 3/4	2.405	47.02	2351	3761	4702				
		2	3.142	36.00	1800	2880	3600				
		2 1/2	4.909	23.04	1152	1843	2304	4608			
		3	7.069	16.00	800	1280	1600	3200			
		3 1/2	9.621	11.75	588	940	1175	2350			
14	153.94	1 3/4	2.405	64.00	3200	5120					
		2	3.142	48.99	2449	3919	4899				
		2 1/2	4.909	31.36	1568	2509	3136				
		3	7.069	21.78	1089	1742	2178	4356			
		3 1/2	9.621	16.00	800	1280	1600	3200			

**(Series PC) Cylinder to Cylinder Intensifiers**

Driving Cylinder		Driving Cylinder		Intensifier Ratio	Theoretical Intensified Hydraulic Pressure (PSI) Using An Input Pressure Of					
Bore	Area	Bore	Area		50	80	100	200	500	1000
Col. 1	Col. 2	Col. 3	Col. 4	Col. 5	Col. 6	Col. 7	Col. 8	Col. 9	Col. 10	Col. 11
3 1/4	8.296	1 1/2	1.767	4.69	235	375	469	938	2345	
		2	3.142	2.64	132	211	264	528	1320	2640*
4	12.566	1 1/2	1.767	7.11	356	569	711	1422	3555*	
		2	3.142	4.00	200	320	400	800	2000	4000*
		2 1/2	4.909	2.56	128	205	256	512	1280	2560*
5	19.635	1 1/2	1.767	11.11	556	889	1111	2222		
		2	3.142	6.25	313	500	625	1250	3125*	
		2 1/2	4.909	4.00	200	320	400	800	2000*	4000*
		3 1/4	8.296	2.37	119	190	237	474	1185	2370*
6	28.274	2	3.142	9.00	450	720	900	1800	4500*	
		2 1/2	4.909	5.76	288	461	576	1152	2880*	
		3 1/4	8.296	3.41	171	273	341	682	1705	3410*
		4	12.566	2.25	113	180	225	450	1125	2250*
		5	19.635	1.44	72	115	144	188	720	1440
8	50.265	2	3.142	16.00	800	1280	1600	3200*		
		2 1/2	4.909	10.24	512	819	1024	2048		
		3 1/4	8.296	6.06	303	485	606	1212	3030*	
		4	12.566	4.00	200	320	400	800	2000*	4000*
		5	19.635	2.56	128	205	256	512	1280	2560*
		6	28.274	1.78	89	143	178	356	890	1780*
10	78.540	2 1/2	4.909	16.00	800	1280	1600	3200*		
		3 1/4	8.296	9.47	474	758	947	1894	4735*	
		4	12.566	6.25	313	500	625	1250	3125*	
		5	19.635	4.00	200	320	400	800	2000*	4000*
		6	28.274	2.78	139	223	278	556	1390*	2780*
12	113.10	3 1/4	8.296	13.64	682	1091	1364	2728*		
		4	12.566	9.00	450	720	900	1800*	4500*	
		5	19.635	5.76	288	460	576	1152	2880*	
		6	28.274	4.00	200	320	400	800	2000*	4000*
		7	38.485	2.94	147*	235*	294*	588*	1470*	2940*
		8	50.265	2.25	113	180	225	450	1125*	2250*
14	153.94	4	12.566	12.25	613	980	1225	2450*		
		5	19.635	7.84	392	627	784	1568*	3920*	
		6	28.274	5.45	273	436	545	1090	1725*	
		7	38.485	4.00	200*	320*	400*	800*	2000*	4000*
		8	50.265	3.06	153	245	306	612	1530*	3060*

\*Not recommended for Series 3L driven cylinder, use Series 2H.

**Cylinder to Cylinder Intensifier – Series PC**

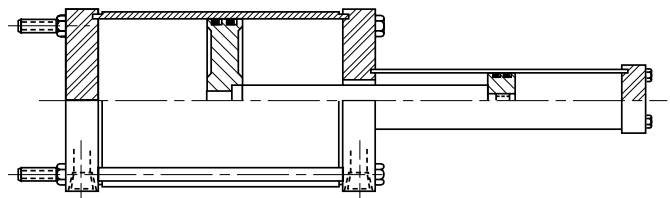

**For additional information – call your local Parker Cylinder Distributor.**

# Fluidpower Intensifiers

## Parker Fluid Power Cylinder to Cylinder Intensifiers (Series PC)

Series PC Intensifiers consist of two cylinders joined into an integral unit with one piston driving a second piston of smaller diameter. These intensifiers are not self-bleeding or self-filling, therefore, for the most effective operation, it is recommended that these tasks be done manually.

**Special Note: It is recommended that Series PC cylinder-to-cylinder intensifiers be mounted vertically with the smaller cylinder up.**

Bore	1 1/2	2	2 1/2	3 1/4	4	5	6	8	10	12	14
	Series 2A & 3L						Series 2A Only				
E	2	2 1/2	3	3 3/4	4 1/2	5 1/2	6 1/2	8 1/2	10 5/8	12 3/4	14 3/4
F	3/8	3/8	3/8	5/8	5/8	5/8	3/4	-	-	-	-
J	1	1	1	1 1/4	1 1/4	1 1/4	1 1/2	1 1/2	2	2	2 1/4
K	7/32	17/64	17/64	21/64	21/64	7/16	7/16	35/64	41/64	41/64	3/4
R	1.43	1.84	2.19	2.76	3.32	4.10	4.88	6.44	7.92	9.40	10.90
AA	2.02	2.6	3.1	3.9	4.7	5.8	6.9	9.1	11.2	13.3	15.4
BB	1	1 1/8	1 1/8	1 3/8	1 3/8	1 13/16	1 13/16	2 5/16	2 11/16	2 11/16	3 3/16
DD	1/4-28	5/16-24	5/16-24	3/8-24	3/8-24	1/2-20	1/2-20	5/8-18	3/4-16	3/4-16	7/8-14
EE	3/8	3/8	3/8	1/2	1/2	1/2	3/4	3/4	1	1	1 1/4
EE <sub>1</sub>	#6	#6	#6	#10	#10	#10	#12	#12	-	-	-
EB	-	-	-	-	-	-	-	11/16	13/16	13/16	15/16
FB	5/16	3/8	3/8	7/16	7/16	9/16	9/16	-	-	-	-
LD	2 5/8	2 5/8	2 3/4	3	3	3 1/4	3 1/2	3 5/8	4 5/8	5 1/8	5 7/8
LF	3 1/2	3 1/2	3 5/8	4 3/8	4 3/8	4 5/8	5 1/4	-	-	-	-
LJ	3 1/8	3 1/8	3 1/4	3 3/4	3 3/4	4	4 1/2	4 5/8	6 1/8	6 5/8	7 5/8
TE	-	-	-	-	-	-	-	7.57	9.40	11.10	12.87
TF	2 3/4	3 3/8	3 7/8	4 11/16	5 7/16	6 5/8	7 5/8	-	-	-	-
TT	-	-	-	-	-	-	-	10.7	13.3	15.7	18.2
UF	3 3/8	4 1/8	4 5/8	5 1/2	6 1/4	7 5/8	8 5/8	-	-	-	-

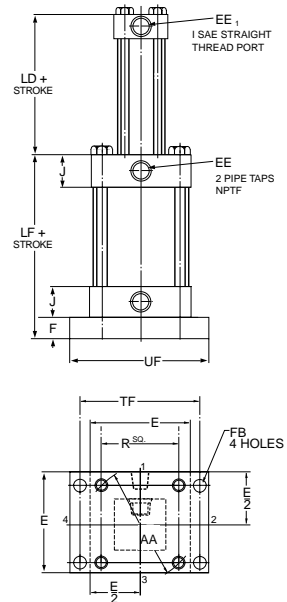

### Mounting Style H Cap Rectangular Flange

This mounting available in driving cylinder bore sizes 3 1/4-inches through 6-inches.

MTG Styles are:  
HA -Air Input  
HL -Hyd. Input

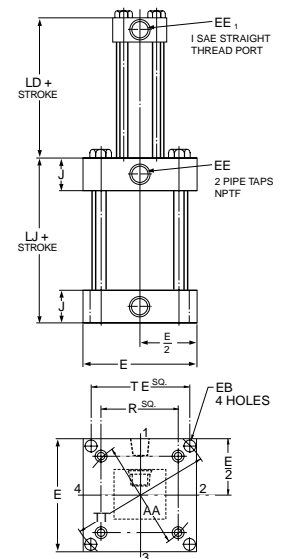

### Mounting Style HB Cap Square Flange

This mounting available in driving cylinder bore sizes 8-inches through 14-inches.

MTG Styles are:  
HBA -Air Input  
HBL -Hyd. Input

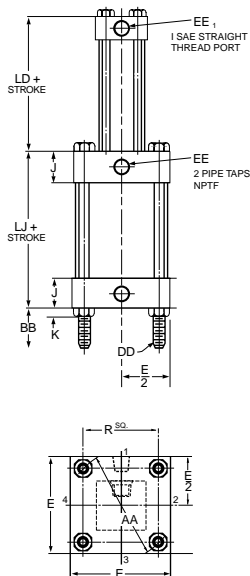

### Mounting Style TC Cap Tie Rods Extended

This mounting available in driving cylinder bore sizes 3 1/4-inches through 14-inches.

MTG Styles are:  
TCA Cap End -Air Input  
TCL Cap End Hyd. Input

Bore	1 1/2	2	2 1/2	3 1/4	4	5	6	7	8
	Series 2H								
E	2 1/2	3	3 1/2	4 1/2	5	6 1/2	7 1/2	8 1/2	9 1/2
F	3/8	5/8	5/8	3/4	7/8	7/8	1	1	1
J	1 1/2	1 1/2	1 1/2	1 3/4	1 3/4	1 3/4	2	2 1/4	2 1/2
K	21/64	7/16	7/16	35/64	35/64	3/4	55/64	31/32	1 1/16
R	1.63	2.05	2.55	3.25	3.82	4.95	5.73	6.58	7.50
AA	2.3	2.9	3.6	4.6	5.4	7.0	8.1	9.3	10.6
BB	1 3/8	1 13/16	1 13/16	2 5/16	2 5/16	3 3/16	3 5/8	4 1/8	4 1/2
DD	3/8-24	1/2-20	1/2-20	5/8-18	5/8-18	7/8-14	1-14	1 1/8-12	1 1/4-12
EE	1/2	1/2	1/2	3/4	3/4	3/4	1	1 1/4	1 1/2
EE <sub>1</sub>	#10	#10	#10	#16	#16	#16	#16	#20	#24
FB	7/16	9/16	9/16	11/16	11/16	15/16	1 1/16	1 3/16	1 5/16
LD	3 3/8	3 3/8	3 1/2	4	4 1/4	4 3/4	5 5/8	6 1/4	7
LF	4 3/4	5	5 1/8	6	6 3/8	6 7/8	8 1/8	9	10
LJ	4 3/8	4 3/8	4 1/2	5 1/4	5 1/2	6	7 1/8	8	9
TF	3 7/16	4 1/8	4 5/8	5 7/8	6 3/8	8 3/16	9 7/16	10 5/8	11 13/16
UF	4 1/8	5 1/8	5 5/8	7 1/8	7 5/8	9 3/4	11 1/4	12 5/8	14

Maximum non-shock pressure rating for Series 3L and 2H can be found on page 106.

For Cylinder Division Plant Locations – See Page II.

**Parker Fluid Power Cylinder to Ram Dual Pressure Intensifiers (Series PD)**

Series PD Intensifiers are similar to the Series PS units except a center head has been added to retain another gland and a third ram seal. When the ram is fully retracted, it withdraws from this third seal, allowing the low pressure the low pressure hydraulic fluid to flow through the port in the center head. The fluid then goes past the ram and out the pressure chamber port to prefill and advance the work cylinder. Actually, this third seal and the ram act as a check valve. As the circuit sequences, the ram advances into the seal to close this "valve" and build up high pressure. With this arrangement and the proper mounting, Series PD intensifiers are self-bleeding and self-filling. And these intensifiers may be used in either single or dual pressure circuits.

**Special Notes:** 1. When equipped with integral air-oil tanks, Series PD intensifiers have a maximum input pressure of 150 psi.  
2. It is recommended that Series PD dual pressure intensifiers be mounted vertically with the pressure chamber down.

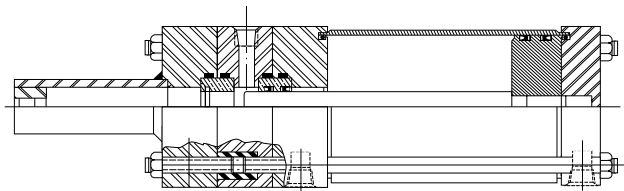

**Dimensions Independent of Ram Size**

Bore	3 1/4	4	5	6	8	10	12	14
	Series 2A & 3L				Series 2A Only			
E	3 3/4	4 1/2	5 1/2	6 1/2	8 1/2	10 5/8	12 3/4	14 3/4
G <sub>1</sub>	1 3/4	1 3/4	1 3/4	2	2	2 1/4	2 1/4	2 3/4
J	1 1/4	1 1/4	1 1/4	1 1/2	1 1/2	2	2	2 1/4
K	3/8	3/8	7/16	7/16	9/16	11/16	11/16	3/4
R	2.76	3.32	4.10	4.88	6.44	7.92	9.40	10.90
S	2 3/4	3 1/2	4 1/4	5 1/4	7 1/8	8 7/8	11	12 5/8
AA	3.9	4.7	5.8	6.9	9.1	11.2	13.3	15.4
AB	9/16	9/16	11/16	13/16	13/16	1 1/16	1 1/16	1 5/16
AH	1 15/16	2 1/4	2 3/4	3 1/4	4 1/4	5 5/16	6 3/8	7 3/8
AL	1 1/4	1 1/4	1 3/8	1 3/8	1 13/16	2 1/8	2 1/8	2 7/16
AO	1/2	1/2	5/8	5/8	11/16	7/8	7/8	1 1/16
AT	1/8	1/8	3/16	3/16	1/4	1/4	3/8	3/8
BB	1 3/8	1 3/8	1 13/16	1 13/16	2 5/16	2 11/16	2 11/16	3 3/16
DD	3/8-24	3/8-24	1/2-20	1/2-20	5/8-18	3/4-16	3/4-16	7/8-14
EE	1/2	1/2	1/2	3/4	3/4	1	1	1 1/4
EE <sub>1</sub>	#8	#8	#8	#8	#8	#12	#12	#16
FI	1 3/8	1 3/8	1 3/8	1 21/32	1 21/32	1 15/16	1 15/16	2 13/32
ST	5	5	5 1/4	5 3/4	6 5/8	8 1/4	8 1/4	9 3/8
ZI	4 13/64	4 13/64	4 3/4	5 1/4	5 55/64	7 21/64	7 21/64	8 7/16
ZK	6	6	6 1/2	7	8	10	10	11 1/2
ZN	8 3/8	8 3/8	8 7/8	9 1/2	10 1/8	12	12 1/2	14 1/2
ZO	6 61/64	6 61/64	7 5/16	7 15/16	8 11/64	9 41/64	10 9/64	11 3/4
ZS	9 29/64	9 29/64	10 5/16	10 15/16	11 11/64	13 41/64	14 9/64	16 1/4
ZZ	10 1/8	10 7/8	11 7/8	12 1/2	13 1/8	16	16 1/2	19

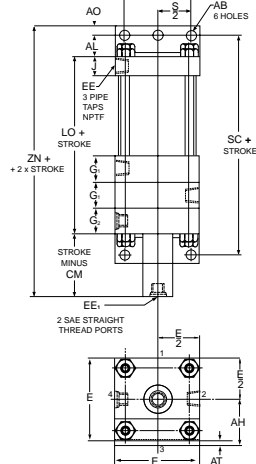
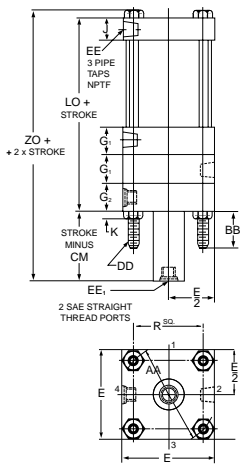

**Mounting Style TB  
Head Tie Rods Extended**

(Styles TC - Cap Tie Rods Extended and TD - Both Ends Tie Rods Extended are also available. Dimensions BB" remains the same in all cases.)

**Mounting Style CB -  
End Angles**

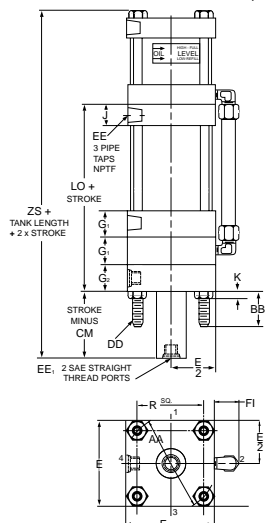
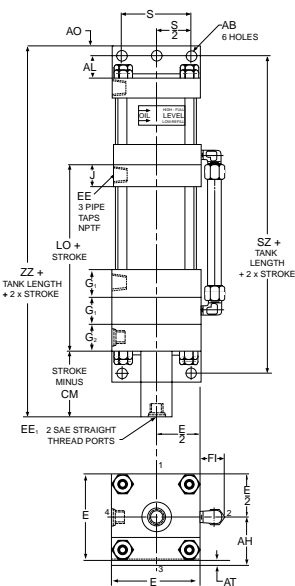

**Mounting Style TB  
Head Tie Rods Extended with  
Integral Air-Oil Tank**

**Mounting Style CB -  
End Angles with Integral Air-  
Oil Tanks**

**Dimensions Dependent on Ram Size**

Bore	3 1/4	4	5	6	8	10	12	14
	Series 2A & 3L				Series 2A Only			
						Ram Sizes		
						1 3/8	2, 2 1/2	2 1/2, 3
						1 3/4, 2	3, 3 1/2, 4	3 1/2, 4
G <sub>2</sub>	-	-	-	-	2	2	2 1/4	2 1/4
CM	-	-	-	-	1 1/2	1 5/8	1 7/8	2 1/8
LO	-	-	-	-	9 1/8	10 5/8	11 3/8	13 1/8
SC	-	-	-	-	10 3/4	12 7/8	13 3/8	15 3/4
SZ	-	-	-	-	13 3/4	16 7/8	17 3/8	20 1/4
						Ram Sizes		
						2 1/2, 3 3 1/2, 5 5 1/2	2 1/2, 3 3 1/2	
G <sub>2</sub>	1 3/4	1 3/4	1 3/4	2	2	2 1/4	2 1/4	2 3/4
CM	1 1/8	1 1/8	1 1/8	1 1/2	1 1/2	1 7/8	1 7/8	2 5/8
LO	7 3/4	7 3/4	8	9	9 1/8	10 7/8	11 3/8	13 5/8
SC	10 1/4	10 1/4	10 3/4	11 3/4	12 3/4	15 1/8	15 5/8	18 1/2
SZ	12 3/4	12 3/4	13 3/4	14 3/4	15 3/4	19 1/8	19 5/8	23

**For additional information – call your local Parker Cylinder Distributor.**

## Parker Fluid Power Cylinder to Ram Single Pressure Intensifiers (Series PS)

Series PS Intensifier delivers a single pressure through a double acting piston driving a ram. One seal on the ram gland works on the driving piston side; the other on the pressure chamber side. Since this intensifier is neither self-bleeding nor self-filling, for best performance it is recommended that these tasks be performed manually.

**Special Note: It is recommended that Series PS single pressure intensifiers be mounted vertically with the pressure chamber up.**

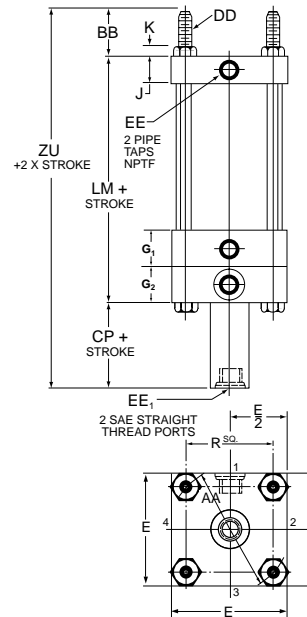
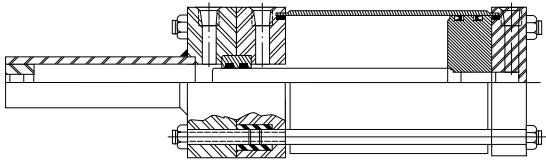

### Dimensions Independent of Ram Size

Bore	3 1/4	4	5	6	8	10	12	14
	Series 2A & 3L				Series 2A Only			
E	3 3/4	4 1/2	5 1/2	6 1/2	8 1/2	10 5/8	12 3/4	14 3/4
G <sub>1</sub>	1 3/4	1 3/4	1 3/4	2	2	2 1/4	2 1/4	2 3/4
J	1 1/4	1 1/4	1 1/4	1 1/2	1 1/2	2	2	2 1/4
K	3/8	3/8	7/16	7/16	9/16	11/16	11/16	3/4
R	2.76	3.32	4.10	4.88	6.44	7.92	9.40	10.90
S	2 3/4	3 1/2	4 1/4	5 1/4	7 1/8	8 7/8	11	12 5/8
AA	3.9	4.7	5.8	6.9	9.1	11.2	13.3	15.4
AB	9/16	9/16	11/16	13/16	13/16	1 1/16	1 1/16	1 5/16
AH	1 15/16	2 1/4	2 3/4	3 1/4	4 1/4	5 5/16	6 3/8	7 3/8
AL	1 1/4	1 1/4	1 3/8	1 3/8	1 13/16	2 1/8	2 1/8	2 7/16
AO	1/2	1/2	5/8	5/8	11/16	7/8	7/8	1 1/16
AT	1/8	1/8	3/16	3/16	1/4	1/4	3/8	3/8
BB	1 3/8	1 3/8	1 13/16	1 13/16	2 5/16	2 11/16	2 11/16	3 3/16
DD	3/8-24	3/8-24	1/2-20	1/2-20	5/8-18	3/4-16	3/4-16	7/8-14
EE	1/2	1/2	1/2	3/4	3/4	1	1	1 1/4
EE <sub>1</sub>	#8	#8	#8	#8	#8	#12	#12	#16
ZU	8 3/8	8 3/8	9 1/6	9 9/16	10 3/16	11 13/16	12 5/16	14 1/16
ZX	8 3/4	8 3/4	9 1/4	9 3/4	10 3/8	12 1/8	12 5/8	14 3/8

### Dimensions Dependent on Ram Size

Bore	3 1/4	4	5	6	8	10	12	14
	Series 2A & 3L				Series 2A Only			
					Ram Sizes			
					1 3/8	2, 2 1/2	2 1/2, 3	
					1 3/4, 2	1 3/4, 2	3, 3 1/2, 4	3 1/2, 4
G <sub>2</sub>	-	-	-	-	2	2	2 1/4	2 1/4
CP	-	-	-	-	3/4	3/4	1/2	1/2
LM	-	-	-	-	7 1/8	8 3/8	9 1/8	10 3/8
SM	-	-	-	-	8 3/4	10 5/8	11 1/8	13
					Ram Sizes			
					2 1/2, 3	2 1/2, 3		
					3 1/2, 5	3 1/2,		
					5 1/2			
G <sub>2</sub>	1 3/4	1 3/4	1 3/4	2	2	2 1/4	2 1/4	2 3/4
CP	1	1	1	3/4	3/4	1/2	1/2	0
LM	6	6	6 1/4	7	7 1/8	8 5/8	9 1/8	10 7/8
SM	8 1/2	8 1/2	9	9 3/4	10 3/4	12 7/8	13 3/8	15 3/4

### Mounting Style TC Cap Tie Rods Extended

(Style TB -Head Rods Extended, and TD -Both Ends Tie Rods Extended, are also available. Dimension BB remains the same in all cases.)

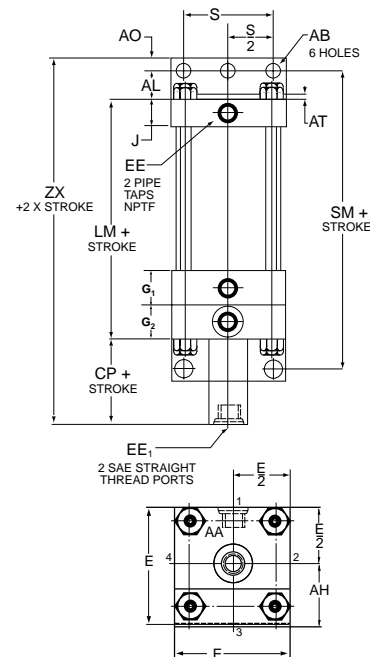

### Mounting Style CB – End Angles

For Cylinder Division Plant Locations – See Page II.

# How To Order Parker Fluidpower Intensifiers

## How To Order

When ordering Parker Intensifiers, please specify:

- a. Quantity
- b. Driving Cylinder bore size
- c. Mounting style –specify by using style letters given beneath dimension drawings.
- d. Driving cylinder operating fluid medium
- e. Intensifier series (PS, PD or PC)

- f. Intensifier ram diameter (for cylinder-to-ram intensifiers) or Output cylinder bore (for cylinder-to-cylinder units)
- g. Driving cylinder stroke
- h. Input pressure, output pressure and volume

**Note:** Standard intensifiers are designed for use with petroleum base hydraulic oil. If other fluids will be used, please consult the factory.

## Model Numbers

Each Parker Fluidpower Intensifier has a model number. This, along with the driving cylinder bore size and stroke, is an accurate and coded description of the unit. The chart

here shows the elements of these model numbers. It is provided so that you can check our order acknowledgement against your order.

### When Ordering Fluid Power Intensifiers By Model Number

Driving Cylinder Bore	Driving Cylinder Mounting Style	Driving Cylinder Operating Fluid		Intensifier Series	Driven Cylinder Series PC Only	Special Features	Intensifier Ram (or Driven Cylinder) Diameter		Driving Cylinder Stroke
3 1/4, 4, 5, 6, 8, 10, 12 or 14	CB, TB, TC, TD, H or HB	2A (Air) or 3L* (HYD.) Specify One Series Only	–	PD, PS, PC	2H (3000 PSI Maximum) or 3L (900 to 2500 PSI Maximum Depending on Bore Size)	S Use Only if Intensifier Varies From Catalog	Specify From Dimension Tables	X	Specify For PD Style See Note Below

NOTE: PD style intensifiers require 2" additional stroke to seal the high pressure end. See Page 61.  
\*3L supplied with cast iron piston rings unless otherwise specified.

## Specifications

### Maximum Input Pressures:

Air - 250 psi (17 BAR); Oil - 1000 psi (69 BAR).

### Maximum Output Pressures:

5/8" to 3" RAM - 5000 psi (345 BAR);  
3 1/2" to 5 1/2" RAM - 3000 psi (206 BAR).

### Maximum Operating Temperatures:

-10°F to +165°F (-23°C) to (+74°C).

## WARNING

**FAILURE OR IMPROPER SELECTION OR IMPROPER USE OF THE PRODUCTS AND/OR SYSTEMS DESCRIBED HEREIN OR RELATED ITEMS CAN CAUSE DEATH, PERSONAL INJURY AND PROPERTY DAMAGE.**

This document and other information from Parker Hannifin Corporation, its subsidiaries and authorized distributors provide product and/or system options for further investigation by users having technical expertise. It is important that you analyze all aspects of your application, including consequences of any failure and review the information concerning the product or system in the current product catalog. Due to the variety of operating conditions and applications for these products or systems, the user, through its own analysis and testing, is solely responsible for making the final selection of the products and systems and assuring that all performance, safety and warning requirements of the application are met.

The products described herein, including without limitation, product features, specifications, designs, availability and pricing, are subject to change by Parker Hannifin Corporation and its subsidiaries at any time without notice.

**For additional information – call your local Parker Cylinder Distributor.**